



**AVERY  
DENNISON**

Fastener  
Solutions

# **6" Slim Line Cable Ties Marketing Specifications**

For the following part numbers:

10391-0

10392-0

10393-0

10394-0

10396-0

August 1, 2018

# AVERY DENNISON MARKETING SPECIFICATION

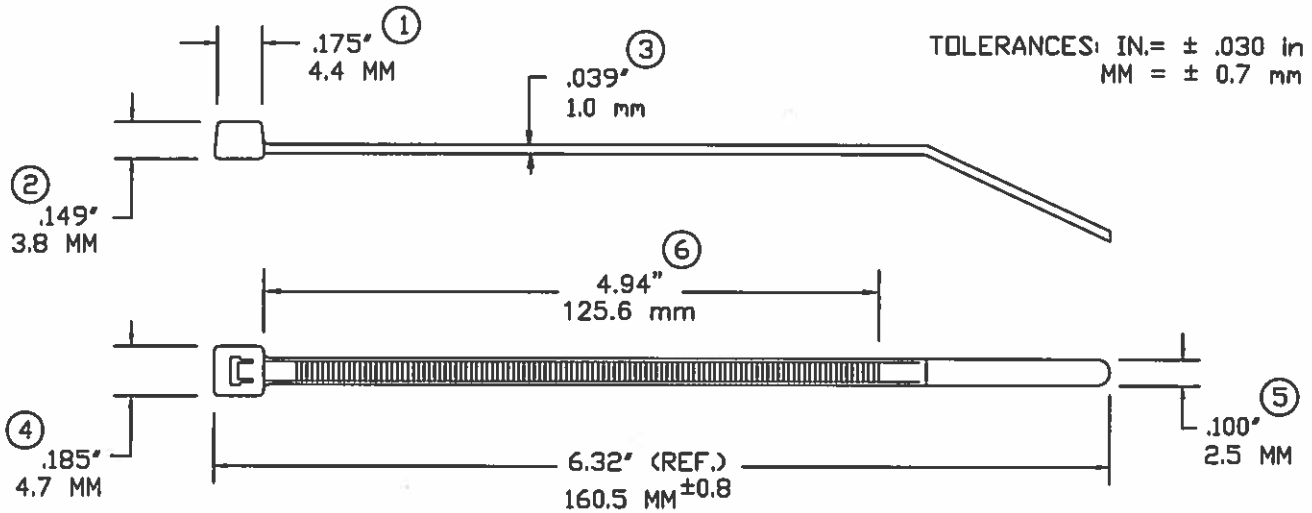

**NOT TO SCALE**

LOOPED TENSILE STRENGTH:	18 Lbsf. / 80N MINIMUM
MILITARY STANDARD:	MS-3367-4-9
MATERIAL:	NYLON 6/6
WEIGHT:	.01363 OZ. / .40 GRAMS
BUNDLE DIAMETER:	∅0.063"/1.59mm TO 1.5"/38.1mm
MIN. INSTALLATION TEMP:	32°F (0°C)
OPERATING TEMPERATURE:	-68°F(-20°C) TO 185°F(85°C)
APPLICATION TOOL:	TOOL, HAND ADJUSTABLE, FOR PLASTIC TIE DOWN STRAP. AVERY DENNISON PART NUMBER 12001.
TOOL TENSION SETTING:	1-3
PACKAGED IN:	1000/BAG, 5000/CASE

Plenum rated and has a flammability rating of V-2  
UL applications require use within enclosures



FASTENER DIVISION  
FITCHBURG, MA 01420 U.S.A.  
TEL. 1-800-225-5913  
MA. 978-353-8157

DESCRIPTION:

6" CABLE TIE, SLIM-LINE  
NATURAL

APPROVAL:

*Ynderburg 4/1/2016*

STOCK NO.

10391-0

REV

J

# AVERY DENNISON MARKETING SPECIFICATION

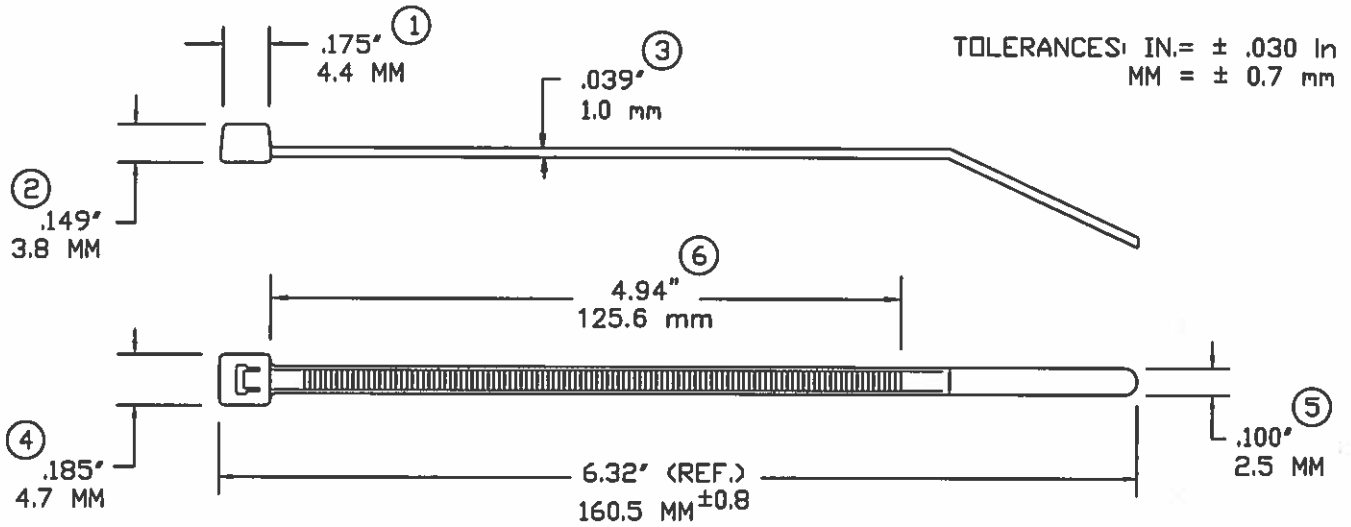

**NOT TO SCALE**

LOOPED TENSILE STRENGTH:	18 Lbsf. / 80N MINIMUM
MILITARY STANDARD:	N/A
MATERIAL:	NYLON 6/6
WEIGHT:	.01363 OZ. / .40 GRAMS
BUNDLE DIAMETER:	∅0.063"/1.59mm TO 1.5"/38.1mm
MIN. INSTALLATION TEMP:	32°F (0°C)
OPERATING TEMPERATURE:	-40°F(-40°C) TO 220°F(105°C)
APPLICATION TOOL:	TOOL, HAND ADJUSTABLE, FOR PLASTIC TIE DOWN STRAP. AVERY DENNISON PART NUMBER 12001.
TOOL TENSION SETTING:	1-3
PACKAGED IN:	1000 PACKS IN SEALED BAGS (100 PACKS AVAILABLE)

Plenum rated and has a flammability rating of V-2  
UL applications require use within enclosures

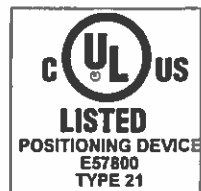

FASTENER DIVISION  
FITCHBURG, MA 01420 U.S.A.  
TEL. 1-800-225-5913  
MA. 978-353-8157

**DESCRIPTION:**

**6" CABLE TIE, SLIM-LINE  
BLACK HEAT STABILIZED**

**APPROVAL:**

*Jinda Boyd* 4/1/2016

STOCK NO. **10392-0**

REV  
**K**

# AVERY DENNISON MARKETING SPECIFICATION

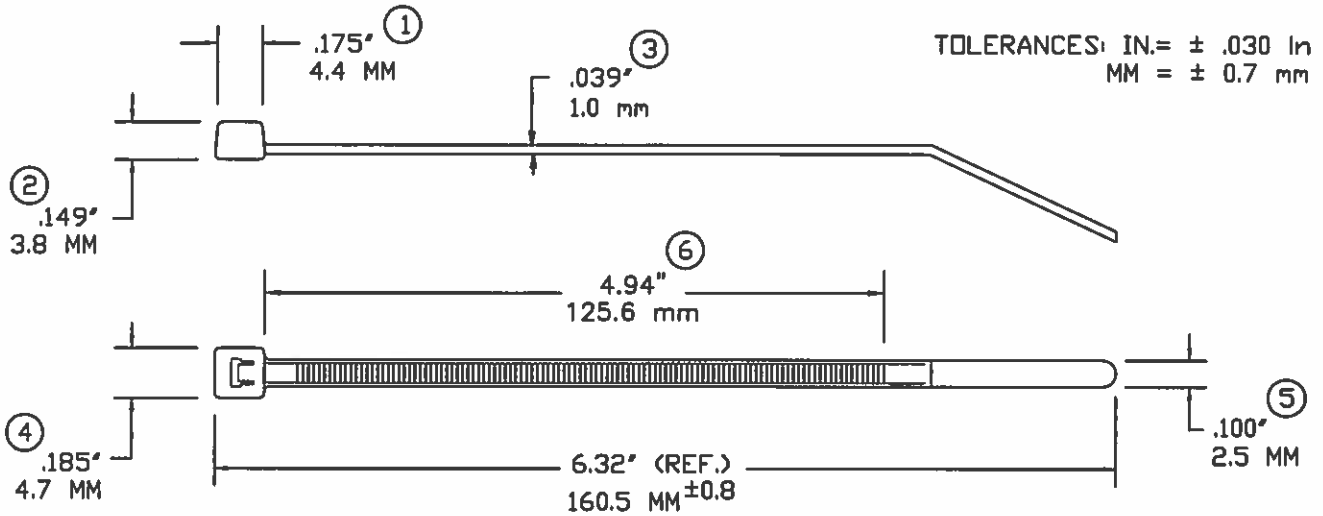

**NOT TO SCALE**

LOOPED TENSILE STRENGTH:	18 Lbsf. / 80N MINIMUM
MILITARY STANDARD:	MS-3367-4-0
MATERIAL:	NYLON 6/6
WEIGHT:	.01363 OZ. / .40 GRAMS
BUNDLE DIAMETER:	∅0.063"/1.59mm TO 1.5"/38.1mm
MIN. INSTALLATION TEMP:	32°F (0°C)
OPERATING TEMPERATURE:	-40°F(-40°C) TO 176°F(80°C)
APPLICATION TOOL:	TOOL, HAND ADJUSTABLE, FOR PLASTIC TIE DOWN STRAP. AVERY DENNISON PART NUMBER 12001.
TOOL TENSION SETTING:	1-3
PACKAGED IN:	1000 PACKS IN SEALED BAGS (100 PACKS AVAILABLE)

UV Resistant and has a flammability rating of V-2  
For use indoors and outdoors



FASTENER DIVISION  
FITCHBURG, MA 01420 U.S.A.  
TEL 1-800-225-5913  
MA. 978-353-8157



DESCRIPTION:

**6" CABLE TIE, SLIM-LINE  
BLACK WEATHER RESISTANT**

APPROVAL:

*Jurda Boyle 4/1/2016*

STOCK NO.

**10393-0**

REV

**J**

# AVERY DENNISON MARKETING SPECIFICATION

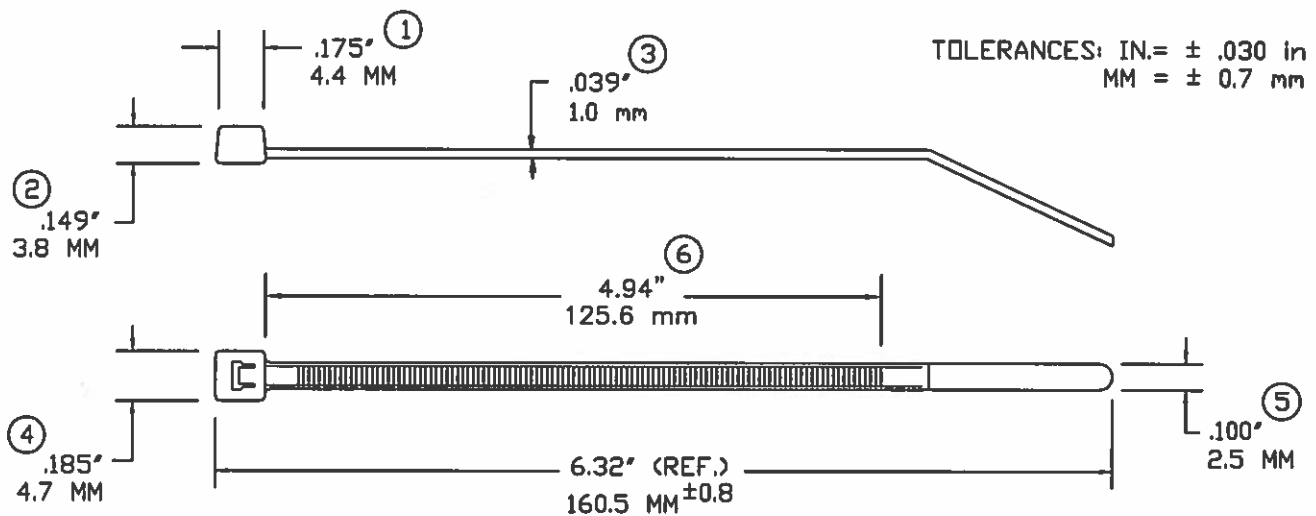

NOT TO SCALE

LOOPED TENSILE STRENGTH:	18 Lbsf. / 80N MINIMUM
MILITARY STANDARD:	MS-3367-4-9
MATERIAL:	NYLON 6/6
WEIGHT:	.01363 OZ. / .40 GRAMS
BUNDLE DIAMETER:	∅0.063"/1.59mm TO 1.5"/38.1mm
MIN. INSTALLATION TEMP:	32°F (0°C)
OPERATING TEMPERATURE:	-68°F(-20°C) TO 185°F(85°C)
APPLICATION TOOL:	TOOL, HAND ADJUSTABLE, FOR PLASTIC TIE DOWN STRAP, AVERY DENNISON PART NUMBER 12001.
TOOL TENSION SETTING:	1-3
PACKAGED IN:	100/BAG, 5000/CASE

Plenum rated and has a flammability rating of V-2  
UL applications require use within enclosures



FASTENER DIVISION  
FITCHBURG, MA 01420 U.S.A.  
TEL. 1-800-225-5913  
MA. 978-353-8157



DESCRIPTION:

6" CABLE TIE, SLIM-LINE  
NATURAL

APPROVAL:

*Linda Boyle 4/1/2016*

STOCK NO.

10394-0

REV

C

# AVERY DENNISON MARKETING SPECIFICATION

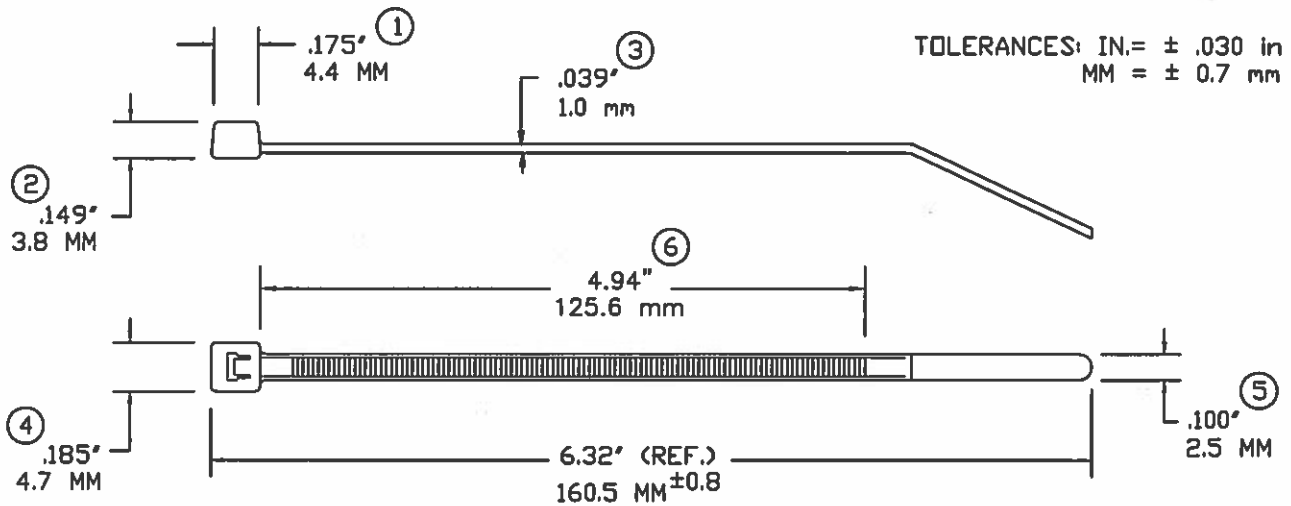

NOT TO SCALE

LOOPED TENSILE STRENGTH:	18 Lbsf. / 80N MINIMUM
MILITARY STANDARD:	MS-3367-4-0
MATERIAL:	NYLON 6/6
WEIGHT:	.01363 OZ. / .40 GRAMS
BUNDLE DIAMETER:	Ø0.063"/1.59mm TO 1.5"/38.1mm
MIN. INSTALLATION TEMP:	32°F (0°C)
OPERATING TEMPERATURE:	-40°F(-40°C) TO 176°F(80°C)
APPLICATION TOOL:	TOOL, HAND ADJUSTABLE, FOR PLASTIC TIE DOWN STRAP. AVERY DENNISON PART NUMBER 12001.
TOOL TENSION SETTING:	1-3
PACKAGED IN:	100/BAG, 5000/CASE

UV Resistant and has a flammability rating of V-2  
For use indoors and outdoors



FASTENER DIVISION  
FITCHBURG, MA 01420 U.S.A.  
TEL. 1-800-225-5913  
MA. 978-353-8157



DESCRIPTION:

6" CABLE TIE, SLIM-LINE  
BLACK WEATHER RESISTANT

APPROVAL:

*Jane Boyle 7/1/2016*

STOCK NO.

10396-0

REV

C